



# S&W Race Cars and Components, Inc.

11 Mennonite Church Road  
Spring City, PA 19475

TECH & INFORMATION: 610-948-7303

ORDERS: 1-800-523-3353

OFFICE FAX: 610-948-7342

E-Z INFO FAX: 610-792-1234

**CAUTION!!!** - *The most important requirement for a successful installation of this, or any, S&W chassis component is that you take your time and use good common sense. Check & recheck all measurements before cutting or welding. If you have any questions, before or during the installation - STOP - and call our tech line at 610-948-7303 and we will gladly explain in more detail any step in the installation.*

## Please read complete instructions thoroughly before beginning! Installation Instructions for S&W Race Cars 4-Link Kits

For proper installation of your S&W 4-link kit, it should be installed in conjunction either S&W 4-link frame rails number 10-025, 10-026, 10-027 or with a S&W welded 4-link frame number 10-400, 10-401, 10-402, 10-507 or 10-508.

*Due to the excessive stress placed on the rod ends in a 4-link suspension, S&W Race Cars insists that only chrome moly rod ends be used in all 4-link kits from Pro/Street to Pro/Stock. S&W 4-link kits may be purchased with or without rod ends. If you purchased your 4-link less rod ends, part number 40-121 rod end package is available separately.*

### FOR PROPER INSTALLATION OF YOUR 4-LINK PLEASE FOLLOW THE STEPS BELOW

- 1.) Level the car front to back and side to side, and install 4-link frame rails as per the instructions included with the rails.
- 2.) Thread the rod ends with jam nuts into the 4-link tubes until you have no more than four or five threads showing between the jam nut and the head of the rod end. *Warning all S&W 4-link tubes feature right hand threads on one end and left hand threads on the other. Care should be taken when installing rod ends to avoid thread damage do to incorrect installation.*
- 3.) Adjust all four 4-link tubes so that they are the same length from rod end bore to rod end bore.
- 4.) Locate the frame brackets on the frame rails in a vertical position making sure all the brackets are at an equal height. *When checking the height of the brackets always measure from the bolt holes, never measure from the ends of the brackets. After determining the bracket location, trim all brackets for fit as necessary and mark their location on the rail. Do not weld in place yet!!!*
- 5.) Place the 4-link brackets on the axle tubes. Next position the rear housing under the car at ride height and with the correct pinion angle. The position of the brackets on the axle tubes will depend on the location and width of the frame brackets. *Do not weld the housing brackets to the housing in this step!!*
- 6.) Install the 4-link tubes on the frame brackets. The tapered bushings included with your kit are intended to be installed between the rod ends and the 4-link brackets. These bushings will provide adequate clearance between the rod ends and brackets to assure proper operation. When installing the 4-link tubes on the frame brackets the bottom tube should be in the second hole up from the bottom, as shown in the drawings. The top tube locations will vary in relation to the horsepower and weight of the car.
- 7.) Install the 4-link tubes to the housing brackets with the bushings (tapered side toward rod end) between the rod ends and the housing brackets. As a starting point install the top tubes in the top holes and the bottom tubes in the bottom holes. *Remember these are just starting points, final placement will vary by application.*
- 8.) Raise the assembled frame brackets to the position you marked on the frame in step 4. With the frame bracket in position, check that the bottom 4-link tubes are level. Also keep the 4-link tubes parallel to the chassis centerline you established while installing the frame rails. Check to make sure the frame brackets are square and if all the requirements are correct tack weld the frame brackets to the frame. **TACK WELD ONLY!**

- 9.) Position the housing brackets the same distance apart as the frame brackets. Install the housing bracket support tube through the holes in the bottom of the housing bracket. *See drawing.* Tack weld the housing brackets to the axle tube and the support to the housing brackets. The support tube is designed for use with 9" Ford housings, different housings may require modification to the tube for installation. **TACK WELD ONLY!**
- 10.) Recheck all measurements and locations
- 11.) If everything is correct, finish weld all brackets. Laser link support tube can be finish welded at this time.

**WHEN YOU MAKE ANY ADJUSTMENTS TO THE LOCATION OF THE LINKS, MAKE ALL CHANGES ONE LINK AT A TIME, WITH THE WEIGHT OF THE CAR ON THE SUSPENSION. THIS IS DONE TO ENSURE THAT THE PINION ANGLE DOES NOT CHANGE!!**

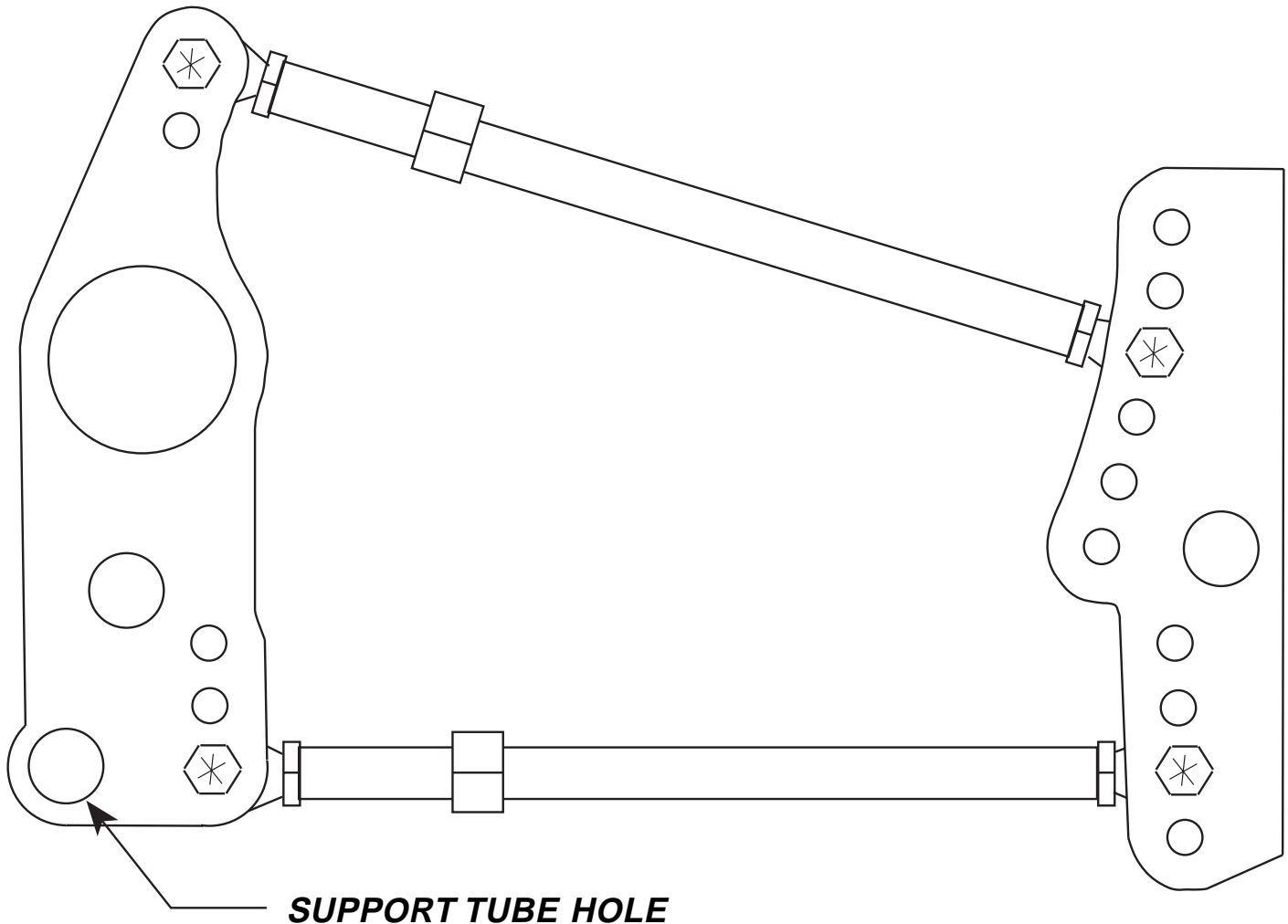

For a guide to 4-link chassis tuning, S&W Race Cars highly recommends **DOORSLAMMERS ,The Chassis Book** by Dave Morgan. Dave's book is a valuable tool when it comes to chassis tuning and 4-link setup. **DOORSLAMMERS, The Chassis Book** is available thru S&W for \$30.00. Also available is Dave Morgan's, **DOORSLAMMERS ,The Chassis Video**. This video covers the set up portion of the book and shows you step-by-step how to set up your 4-link. Video only \$29.95 or by the book & video together for \$49.95 and save \$10.00!!